

The versatile endurance runner – iglidur® J



Order key for tubes

Type	Dimensions [mm]
SF T J -110 70- □	
<div style="display: flex; justify-content: space-between;"> <div style="writing-mode: vertical-rl; transform: rotate(180deg);">Bar stock</div> <div style="writing-mode: vertical-rl; transform: rotate(180deg);">Tube</div> <div style="writing-mode: vertical-rl; transform: rotate(180deg);">iglidur® material</div> </div>	<div style="display: flex; justify-content: space-between;"> <div style="writing-mode: vertical-rl; transform: rotate(180deg);">Outer Ø</div> <div style="writing-mode: vertical-rl; transform: rotate(180deg);">Inner Ø</div> <div style="writing-mode: vertical-rl; transform: rotate(180deg);">Length</div> </div>

In your required length, freely selectable between 50 and 1,000mm. Cut-to-size parts are delivered oversized.

Dimensions [mm]

Inner Ø	Inner diameter tolerance	Outer Ø	Outer diameter tolerance	Length	Part No.
70	-2.0 / -6.5	110	+1.5 / +4.5	50 – 1,000	SFTJ-11070
70	-2.0 / -6.5	125	+1.5 / +4.5	50 – 1,000	SFTJ-12570
100	-2.0 / -6.5	150	+1.5 / +4.5	50 – 1,000	SFTJ-150100

Available from stock
Upon request/check availability

Solve wear problems quickly with iglidur® plate strips



Order key for plate strips

Type	Dimensions [mm]
SF P □ -15-160- □	
<div style="display: flex; justify-content: space-between;"> <div style="writing-mode: vertical-rl; transform: rotate(180deg);">Bar stock</div> <div style="writing-mode: vertical-rl; transform: rotate(180deg);">Plate</div> <div style="writing-mode: vertical-rl; transform: rotate(180deg);">iglidur® material</div> </div>	<div style="display: flex; justify-content: space-between;"> <div style="writing-mode: vertical-rl; transform: rotate(180deg);">Material thickness</div> <div style="writing-mode: vertical-rl; transform: rotate(180deg);">Width</div> <div style="writing-mode: vertical-rl; transform: rotate(180deg);">Length</div> </div>

In your required length, freely selectable between 50 and 1,000mm. Cut-to-size parts are delivered oversized.

Dimensions [mm]

iglidur® material	Material thickness s	Material thickness Tolerance	Width	Part No.
A500	15	+0.300 +1.500	160	SFPA500-15-160-□
A500	30	+0.500 +2.500	160	SFPA500-30-160-□
A500	50	+0.500 +3.500	160	SFPA500-50-160-□
C500	15	+0.300 +1.500	160	SFPC500-15-160-□
E7	30	+0.500 +2.500	160	SFPE7-30-160-□
HSD350	50	+0.500 +3.500	160	SFPHSD350-50-160-□
J350	15	+0.300 +1.500	160	SFPJ350-15-160-□
J4	15	+0.300 +1.500	160	SFPJ4-15-160-□
J4	30	+0.500 +2.500	160	SFPJ4-30-160-□
J4	50	+0.500 +3.500	160	SFPJ4-50-160-□
K230	15	+0.300 +1.500	160	SFPK230-15-160-□
RW370	15	+0.300 +1.500	160	SFPRW370-15-160-□
W300	15	+0.300 +1.500	160	SFPW300-15-160-□
X	15	+0.300 +1.500	160	SFPX-15-160-□

igus® constantly expands its range of available materials and dimensions. Please contact us in case the required diameter is not available.

Plastic plates made from iglidur® can be supplied cut to size, with thickness ranging from 2mm to 40mm and available in up to 7 standard sizes.

 Order key for plates

Type Plate Dimensions [mm] SF P J - □ - 500 - 240

Bar stock	Plate	iglidur® material	Material thickness	Length	Width
-----------	-------	-------------------	--------------------	--------	-------



Dimensions (L x B)	Material thickness s	Part No.
500x240	2 / 3 / 4 / 5 / 6	SFPJ-□-500-240
500x300	10 / 15 / 20 / 25 / 30 / 40	SFPJ-□-500-300
500x500	2 / 3 / 4 / 5 / 6	SFPJ-□-500-500
500x610	10 / 15 / 20 / 25 / 30 / 40	SFPJ-□-500-610
1,000x500	2 / 3 / 4 / 5 / 6	SFPJ-□-1000-500
1,000x610	10 / 15 / 20 / 25 / 30 / 40	SFPJ-□-1000-610
1,000x1,000	2 / 3 / 4 / 5 / 6	SFPJ-□-1000-1000

Tolerances	
Material thickness	Tolerance
2	+0.000 +0.200
3	+0.000 +0.200
4	+0.000 +0.250
5	+0.000 +0.250
6	+0.000 +0.300
10	+0.200 +0.900
15	+0.300 +1.500
20	+0.300 +1.500
25	+0.300 +1.500
30	+0.500 +2.500
40	+0.500 +2.500

Extremely wear-resistant in black – iglidur® JB



Dimensions (L x B)	Material thickness s	Part No.
500x300	10 / 25	SFPJB-□-500-300
500x610	10 / 25	SFPJB-□-500-610
1,000x610	10 / 25	SFPJB-□-1000-610

Tolerances	
Material thickness	Tolerance
10	+0.200 +0.900
25	+0.300 +1.500

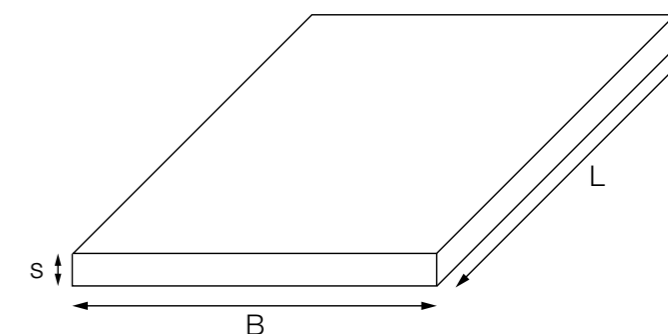

Dimensions (L x B)	Material thickness s	Part No.
500x300	15 / 20 / 25 / 30	SFPA350-□-500-300
500x610	15 / 20 / 25 / 30	SFPA350-□-500-610
1,000x610	15 / 20 / 25 / 30	SFPA350-□-1000-610

Tolerances	
Material thickness	Tolerance
15	+0.300 +1.500
20	+0.300 +1.500
25	+0.300 +1.500
30	+0.500 +2.500

FDA and EU 10/2011-compliant – iglidur® A160



Dimensions (L x B)	Material thickness s	Part No.
500x300	10 / 20	SFPA160-□-500-300
500x610	10 / 20	SFPA160-□-500-610
1,000x610	10 / 20	SFPA160-□-1000-610

Tolerances	
Material thickness	Tolerance
10	+0.200 +0.900
20	+0.300 +1.500

FDA-compliant – iglidur® A180



Dimensions (L x B)	Material thickness s	Part No.
500x300	10 / 20	SFPA180-□-500-300
500x610	10 / 20	SFPA180-□-500-610
1,000x610	10 / 20	SFPA180-□-1000-610

Tolerances	
Material thickness	Tolerance
10	+0.200 +0.900
20	+0.300 +1.500

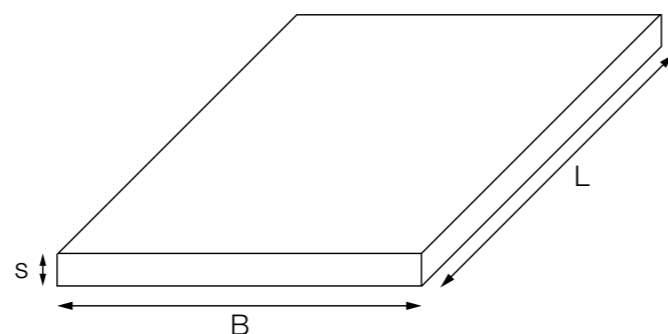

Dimensions (L x B)	Material thickness s	Part No.
500x300	15	SFPRN326-□-500-300
500x610	15	SFPRN326-□-500-610
1,000x610	15	SFPRN326-□-1000-610

Tolerances	
Material thickness	Tolerance
15	+0.300 +1.500

Processing information for iglidur® bar stock

General information for achieving good results when processing iglidur® bar stock:

- Use tools made from high-speed steels (HSS) and hard metal (HM)
- Always ensure the tools are extremely sharp and in perfect condition
- In view of the far greater thermal expansion compared to metals and the dimensional

changes caused by absorbed water, larger production tolerances are required for plastics than for metal parts

- To reduce any retrospective warping as a result of machining stresses, if large material volumes are to be machined, interim tempering should be used before the refined finishing stage

	Sawing	Turning	Milling	Drilling
Tool material	HM with alternate teeth or trapezoidal flat teeth	HSS	HSS	HSS
Clearance angle	5–30°	2–10°	2–30°	3–16°
Rake angle	0–15°	0–8°	0–15°	5–30°
Tooth pitch	2–14mm	–	–	–
Setting angle	–	45–60°	–	–
Tip angle	–	–	–	90–130°
Cutting speed	max. 300m/min.	100–500m/min.	80–500m/min.	20–200m/min.
Feed rate	–	0.05–0.5mm/rpm	0.02–0.3mm/rpm	–

Table: General processing information

Machining guidelines

	Unit	iglidur® material							
		A160, B160, W160, E7, RN326, K230	J, J2, J4, JB, A180, A181, J200, R	J260	W300, M250, GLW	P210, F2, T220	A350, J350	H1, H2, H4	X, A500, C500
Turning									
Clearance angle	[°]	6–10	6–8	5–10	6–10	5–10	6	6	6
Rake angle	[°]	0–5	0–5	6–8	0–5	0–5	0	0–5	0–5
Setting angle	[°]	45–60	45–60	45–60	45–60	45–60	45–60	45–60	45–60
Cutting speed	[m/min]	250–500	300–600	300	250–500	300–400	350–400	250–500	250–500
Feed rate	[mm/rpm]	0.1–0.5	0.1–0.4	0.1–0.5	0.1–0.5	0.2–0.4	0.1–0.3	0.1–0.5	0.1–0.5
Milling									
Number of teeth		Z1–Z2	Z1–Z2	Z1–Z2	Z1–Z2	Z1–Z2	Z1–Z2	Z1–Z2	Z1–Z2
Cutting speed	[m/min]	250–500	300	300	250–500	300	250–500	250–500	250–500
Feed rate	[mm/rpm]	0.1–0.45	0.15–0.5	0.15–0.4	0.1–0.45	0.15–0.5	0.1–0.45	0.1–0.45	0.1–0.45
Drilling									
Number of teeth		Z2	Z2	Z2	Z2	Z2	Z2	Z2	Z2
Angle of twist	[°]	25	25	25	25	25	25	25	25
Acute angle	[°]	90	90	90	90	90	90	90	90
Cutting speed	[m/min]	50–150	50–150	50–100	50–150	50–100	20–80	50–200	50–200
Feed rate	[mm/rpm]	0.1–0.3	0.1–0.3	0.2–0.3	0.1–0.3	0.2–0.3	0.1–0.3	0.1–0.3	0.1–0.3