

Low pressure flat fan nozzles

Press-in nozzle

Series 612.xxx.5E.03



Features:

- Uniform, parabolic liquid distribution
- For pressing into pipes

Applications:

- Cleaning and rinsing procedures
- Industrial dish washers

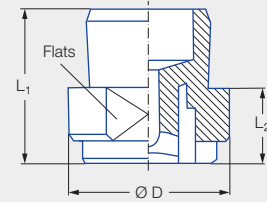

Series 612.xxx.5E.03

Dimensions [mm]				Weight [g]
L ₁	L ₂	Ø D	Flats	
12.5	5.5	14.0	12	2.0

Spray angle	Ordering no.		Equivalent bore diameter A [mm]	Narrowest free cross section Ø [mm]	V̇ water [l/min]						Spray width B [mm] (at p = 2 bar)	
	Type	Mat. no.			p [bar]						H = 250 [mm]	H = 500 [mm]
		5E.03			0.3	0.5	0.7	1.0	1.5	2.0		
90°	612.366	●	1.00	0.50	0.24	0.31	0.37	0.44	0.55	0.63	360	730
	612.486	●	1.50	0.60	0.62	0.80	0.95	1.13	1.39	1.60	360	730
120°	612.487	●	1.50	0.60	0.62	0.80	0.95	1.13	1.39	1.60	720	1,280
	612.647	●	2.50	1.20	1.55	2.00	2.37	2.83	3.46	4.00	720	1,280

Assembly :

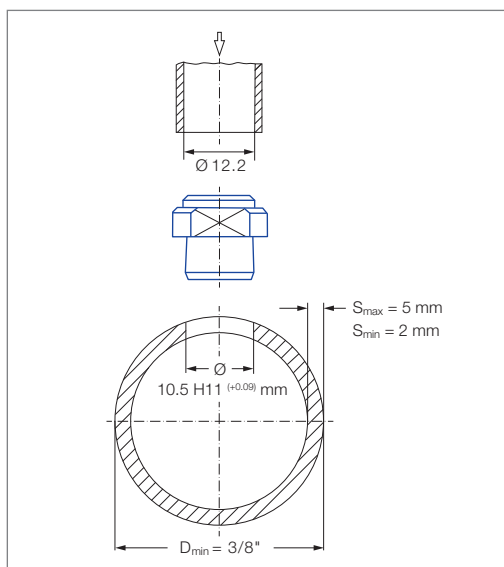

Drill pipe (Ø 10 mm), ream to Ø 10.5 H11 (+0.09) mm, adjust nozzle, place press-in pipe (inner diameter 12.2 mm) on nozzle and tap in using a rubber mallet. Max. flow velocity in the pipe 2–3 m/s.

Conversion formula for this series: $\dot{V}_2 = \dot{V}_1 \cdot \sqrt{\frac{p_2}{p_1}}$

Ordering Type + Material no. = Ordering no.
example: 612.366 + 5E.03 = 612.366.5E.03

 Assembly accessories can be found in Chapter 9 "Accessories".